

UNDER-FLANGE (UF) CONNECTION

NEW MILL-TYPE U.F. CONNECTION #3

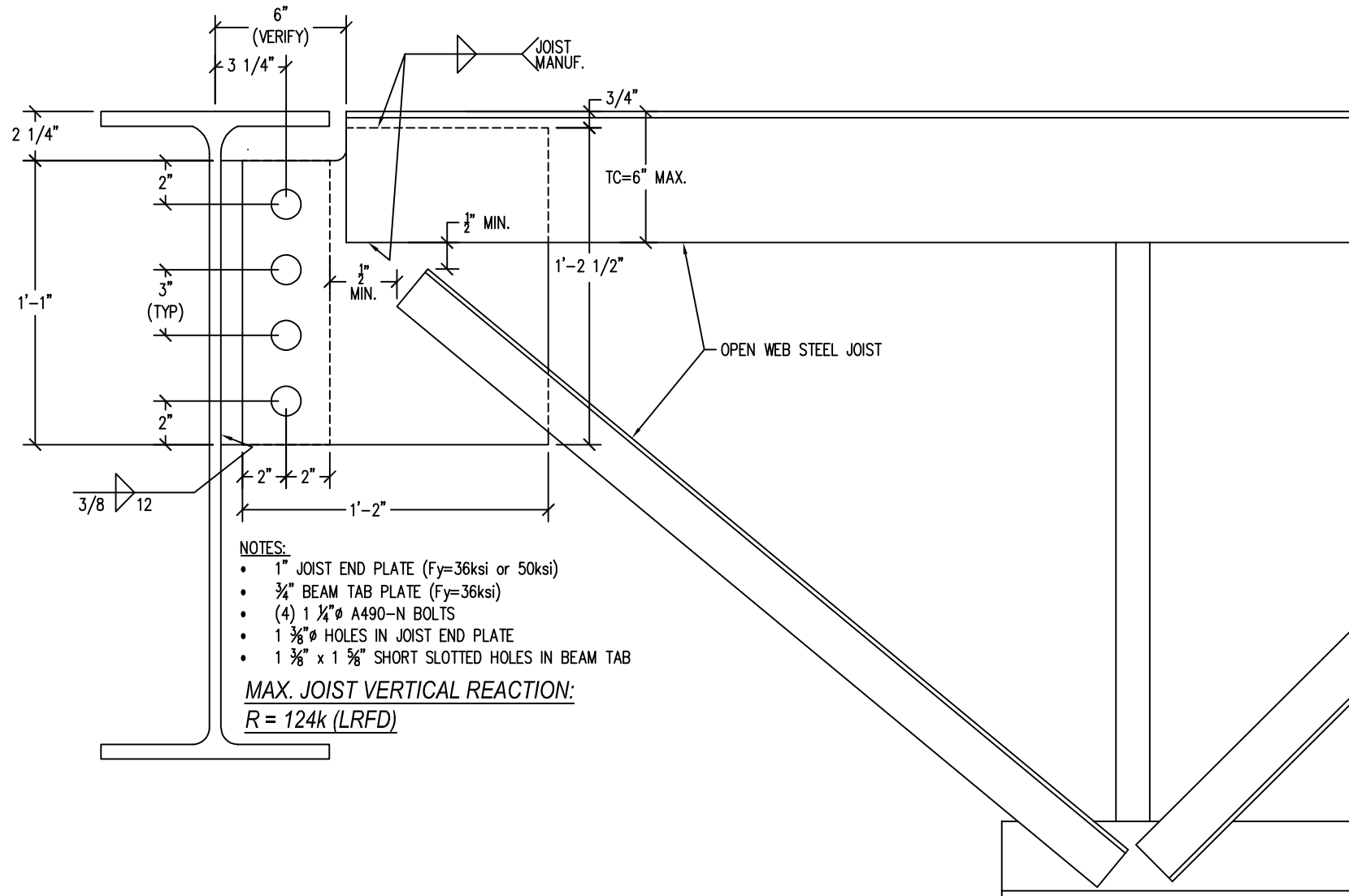

NOTES:

- 1" JOIST END PLATE (F_y=36ksi or 50ksi)
- 3/4" BEAM TAB PLATE (F_y=36ksi)
- (4) 1 1/4"φ A490-N BOLTS
- 1 3/8"φ HOLES IN JOIST END PLATE
- 1 3/8" x 1 5/8" SHORT SLOTTED HOLES IN BEAM TAB

MAX. JOIST VERTICAL REACTION:

R = 124k (LRFD)



NEW MILLENNIUM

A Steel Dynamics Company

WWW.NEWMILL.COM

Date: 9/26/2023

TYPE U.F. CONNECTION #3

AISC 14TH - p. 10-104

Holes must satisfy AISC J3.2

Horizontal Axial forces (seismic or wind) if present, to be transferred from beam to joist via tie plate

Joist Plate, Fu =	58	ksi	TC Hold Back Distance (H) =	6	in
Joist Tab Plate, Fy =	36	ksi	TC Angle Size =	3	in
Joist Plate Width, w =	14	in	Joist Plate Hold-Down from TC =	0.75	in
Joist Plate Thickness, t =	1	in			
Joist Plate Edge Distances, de =	2	in			
e =	3.25	in	L ₁₁ =	4.5	
Vertical Shear, Vu =	124	k (LRFD)	L ₁₂ =	1.5	
Vertical Ecc. Moment, Mu =	403	k*in (LRFD)	L ₁₃ =	0	
Joist Top Chord Axial Force, V _{TC} =	186	k (LRFD)...	L ₁₄ =	0	
Bolt Diam. =	1.25	in	L ₁₅ =	0	
Bolt Shear Capacity φRn =	62.7	k (A490-N)			
# of Bolts, Nb =	4	(Spreadsheet design limitation, max. 10 bolts)			
Spacing of Bolt Group, S =	3	in			
Vert. C.G. of Bolt Group =	4.5	in			
F _y /0.9 =	75.56	ksi (Table J3.2, A490-N Bolts)			
Short Slotted Hole, Lh =	1.63	in			

Gross Plate Area, Ag =	14	in ²
Effective Plate Area, Ae =	12.63	in ²
Z =	49	in ³ (1/4t*w ²)
S =	32.6667	in ³ (1/6t*w ²)

Bolt Shear - Elastic Vector Method: (AISC p. 7-8, 7-9)

Bolt Group l _p =	45.00	in ⁴ /in ²
r _{py} =	31.00	k (Vu/# Bolts)
r _{mx} =	40.30	k (Mu*L ₁₁ /l _p)
Hm =	40.30	k (r _{mx} *Nc) Nc = 1 column of bolts
Ru =	50.84	k (r _{py} ² +r _{mx} ²) ^{1/2}
Ru / φRn =	0.81	<1.0 OK

Shear Plate Yielding:

φVn =	302.4	k (φ = 1.0, φ*0.6*F _y *Ag)
Horiz. Axial Shear V _{TC} /φVn =	0.62	<1.0 OK
φMn =	1058.4	k*in (φ = 0.9, φ*F _y *S)
Mu/φMn =	0.38	<1.0 OK
Ru / φRn =	0.52	<1.0 OK (Vu/φVn) ² +(Mu/φMn) ²

Shear Plate Rupture: (AISC p.9-6)

Crushed Hole Width, W' =	1.4375	in (plate hole + 1/16" Crushed width)
Net Plastic Modulus, Z _{net} =	39.97	in ³ (Z - W'*t*d _{hole}) d _{hole} = 6.28125 in
φVn =	329.51	k (φ = 0.75, φ*.60*F _u *Ae)
φMn =	1738.73	k*in (φ = 0.75, φ*F _u *Z)
Ru / φRn =	0.20	<1.0 OK (Vu/φVn) ² +(Mu/φMn) ²

Shear Plate Block Shear: (AISC J4.3)

Vertical Direction		
Gross Area in Shear, Agv =	11.00	in ² (t*(d _e +(Nb-1)*S)
Net Area in Shear, Anv =	5.25	in ² Agv-(Nb*W')*t
Net Area in Tension, Ant =	1.19	in ² (t*(d _e -(Nc-0.5)*Lh), Nc = 1 column of bolts
Gross Area, φRn =	247.08	k
Net Area, φRn =	205.90	k

Horizontal Direction

Gross Area in Shear, Agv =	4.00	in ² (2*t*d _e)
Net Area in Shear, Anv =	2.38	in ² (2*t*(d _e -(Nc-0.5)*Lh), Nc = 1 column of bolts
Net Area in Tension, Ant =	4.69	in ² (t*((Nb-1)*S-(Nb-1)*W)
Gross Area, φRn =	336.68	k
Net Area, φRn =	333.86	k

φRn =	205.90	k Controls
Ru / φRn =	0.63	<1.0 OK (Vu ² +Hm ²) ^{1/2} /φRn

Shear Plate Local Buckling: (AISC p.10-103, p.9-6)

Shear Stress, fv =	13.29	ksi (V _{TC} /Ag)
Critical Stress, Fcr =	14.12	ksi ((φ*F _y) ² -3*f _v ²) ^{1/2} φ=0.75, von Mises Yield

λ =	0.10	AISC Eq. 9-18
Q =	1	AISC Eq. 9-15 through 9-17
Fcr =	36	ksi (Q*F _y) Classic Plate Buckling

von Mises φMn =	415.23	k*in (φ*Fcr*S) φ = 0.9
Classic Plate Buckling φMn =	1058.40	k*in (φ*Fcr*S) φ = 0.9
Governing φMn =	415.23	k*in

Mu / φMn =	0.97	<1.0 OK
------------	------	---------

Joist Plate Weld (Angle = 0 deg. & C₁ = 1.00 E70 Electrode):

Length of Plate Weld L _w =	9	in (w-(H-1.25)-0.25")
a _v =	0.2	AISC Table 8-4 a _v = (Weld Centroid - TC Centroid) / L _w
k _v =	0.3	AISC Table 8-4 k _v = Weld Spacing / L _w
C _y =	3.49	(y-axis weld eccentricity, AISC Table 8-4)
D _{min} =	4	/16ths of an inch Fillet Weld Size (min)

Stress Ratio Results:	
Bolt Shear (V&M):	0.81
Shear Plate Yielding:	0.52
Shear Plate Rupture:	0.20
Shear Plate Block Shear:	0.63
Shear Plate Local Buckling:	0.97

Min. Joist TC to Plate Weld:
4 /16th x 9 " Fillet Weld

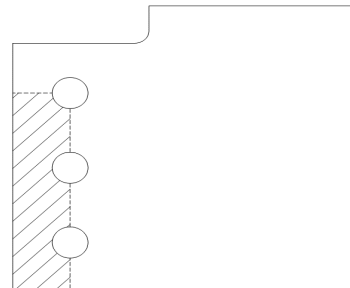

Note: Use of Lh for determination of Net Plate Area, allows for the slots to be in the joist end plate, rather than the beam tab.

Note: Use of Lh for determination of Net Plate Area, allows for the slots to be in the joist end plate, rather than the beam tab.

AISC 14TH - p. 10-104

Holes must satisfy AISC J3.2

Horizontal Axial forces (seismic or wind) if present, to be transferred from beam to joist via tie plate
cp

Beam Tab Plate, $F_u =$	58	ksi	
Beam Tab Plate, $F_y =$	36	ksi	
Beam Tab Plate Depth, $d =$	13	in	
Beam Tab Thickness, $t =$	0.75	in	
Beam Tab Edge Distances, $d_e =$	2	in	$L_{11} = 4.5$
$e =$	3.25	in	$L_{12} = 1.5$
Vertical Shear, $V_u =$	124	k (LRFD)	$L_{13} = 0$
Vertical Ecc. Moment, $M_u =$	403	k*in (LRFD)	$L_{14} = 0$
Bolt Diam. =	1.25	in	$L_{15} = 0$
Bolt Shear Capacity $\phi R_n =$	62.7	k	
# of Bolts, $N_b =$	4	(Spreadsheet design limitation, max. 10 bolts)	
Spacing of Bolt Group, $S =$	3	in	
C.G. of Bolt Group =	4.5	in	
$F_v/0.9 =$	75.56	ksi (Table J3.2, A490-N Bolts)	
Short Slotted Hole, $L_h =$	1.63	in	

$A_b =$	1.23	in ² (Bolt Area)
$C' =$	11.26	AISC Eq. 7-21, p. 7-19
$M_{max} =$	1043.69	k*in ($F_v/0.9 * A_b * C'$, Eq. 10-4)
Max. Beam Tab Thickness, $t_{max} =$	1.03	in ($6 * M_{max} / (F_y * d^2)$ AISC Eq. 10-3)

Gross Plate Area, $A_g =$	9.75	in ²
Effective Plate Area, $A_e =$	5.63	in ²
$Z =$	31.6875	in ³ ($1/4 * t * d^2$)
$S_{net} =$	21.13	in ³ ($1/6 * t * d^2$)

Stress Ratio Results:	
Bolt Shear (V&M):	0.81
Shear Tab Yielding:	0.50
Shear Tab Rupture:	0.96
Shear Tab Block Shear:	0.84
Shear Tab Local Buckling:	0.59
6 / 16" Tab Weld:	0.57

Bolt Shear - Elastic Vector Method: (AISC p. 7-8, 7-9)

Bolt Group $I_p =$	45.00	in ⁴ /in ²
$r_{py} =$	31.00	k ($V_u / \# \text{ Bolts}$)
$r_{mx} =$	40.30	k ($M_u * L_{11} / I_p$)
$H_m =$	40.30	k ($r_{mx} * N_c$) $N_c = 1$ column of bolts
$R_u =$	50.84	k ($(r_{py}^2 + r_{mx}^2)^{1/2}$)
$R_u / \phi R_n =$	0.81	< 1.0 OK

Shear Tab Yielding:

$\phi V_n =$	210.6	k ($\phi = 1.0, \phi * 0.6 * F_y * A_g$)
$\phi M_n =$	1026.68	k*in ($\phi = 0.9, \phi * F_y * Z$)
$R_u / \phi R_n =$	0.50	< 1.0 OK ($(V_u / \phi V_n)^2 + (M_u / \phi M_n)^2$)

Shear Tab Rupture: (AISC p.9-6)

Crushed Hole Width, $W' =$	1.4375	in (plate hole + 1/16" Crushed width)
Net Plastic Modulus, $Z_{net} =$	18.75	in ³ (Summation of $A * d$ of net plate section)
$\phi V_n =$	146.81	k ($\phi = 0.75, \phi * .60 * F_u * A_e$)
$\phi M_n =$	815.63	k*in ($\phi = 0.75, \phi * F_u * Z$)
$R_u / \phi R_n =$	0.96	< 1.0 OK ($(V_u / \phi V_n)^2 + (M_u / \phi M_n)^2$)

Shear Tab Block Shear: (AISC J4.3)

Vertical Direction		
Gross Area in Shear, $A_{gv} =$	8.25	in ² ($t * (d_e + (N_b - 1) * S)$)
Net Area in Shear, $A_{nv} =$	3.94	in ² $A_{gv} - (N_b * W) * t$
Net Area in Tension, $A_{nt} =$	0.89	in ² ($t * (d_e - (N_c - 0.5) * L_h)$, $N_c = 1$ column of bolts)
Gross Area, $\phi R_n =$	185.31	k
Net Area, $\phi R_n =$	154.43	k

Horizontal Direction

Gross Area in Shear, $A_{gv} =$	3.00	in ² ($2 * t * d_e$)
Net Area in Shear, $A_{nv} =$	1.78	in ² ($2 * t * (d_e - (N_c - 0.5) * L_h)$, $N_c = 1$ column of bolts)
Net Area in Tension, $A_{nt} =$	3.52	in ² ($t * ((N_b - 1) * S - (N_b - 1) * W)$)
Gross Area, $\phi R_n =$	252.51	k
Net Area, $\phi R_n =$	250.40	k

$\phi R_n =$	154.43 k Controls
$R_u / \phi R_n =$	0.84 < 1.0 OK ($(V_u^2 + H_m^2)^{1/2} / \phi R_n$)

Shear Tab Local Buckling: (AISC p.10-103, p.9-6)

Shear Stress, $f_v =$	12.72	ksi (V_u / A_g)
Critical Stress, $F_{cr} =$	28.47	ksi ($F_y^2 - 3 * f_v^2$) ^{1/2} von Mises Yield AISC p. 10-103

$\lambda =$	0.15	AISC Eq. 9-18
$Q =$	1	AISC Eq. 9-15 through 9-17
$F_{cr} =$	36	ksi ($Q * F_y$) Classic Plate Buckling

von Mises $\phi M_n =$	812.04	k*in ($\phi * F_{cr} * Z$) $\phi = 0.9$
Classic Plate Buckling $\phi M_n =$	684.45	k*in ($\phi * F_{cr} * Z$) $\phi = 0.9$
Governing $\phi M_n =$	684.45 k*in	

$M_u / \phi M_n =$	0.59 < 1.0 OK
--------------------	-------------------------

Shear Tab Weld: (AISC p.10-102, p.9-6)

Min. Weld Thickness $t_{wmin} =$	0.33	in. $t_{wmin} = (t * F_y * 3^{1/2}) / (2 * F_{EXX})$, $F_{EXX} = 70$ ksi Electrode, AISC Engineering Journal, Vol. 46, 2009
Weld Provided $t_w =$	0.375	in
Min. Plate Thickness =	0.64	in (AISC Eq. 9-3, $6.19 * D / F_u$) GOOD
$\phi R_w =$	217.14	k ($\phi * 0.6 * F_{EXX} * 0.707 * t_w * d * 2$)

$R_u / \phi R_n =$	0.57 < 1.0 OK
--------------------	-------------------------

