

EXTENDED-TAB (ET) CONNECTION

NEW MILL-TYPE E.T. CONNECTION #5

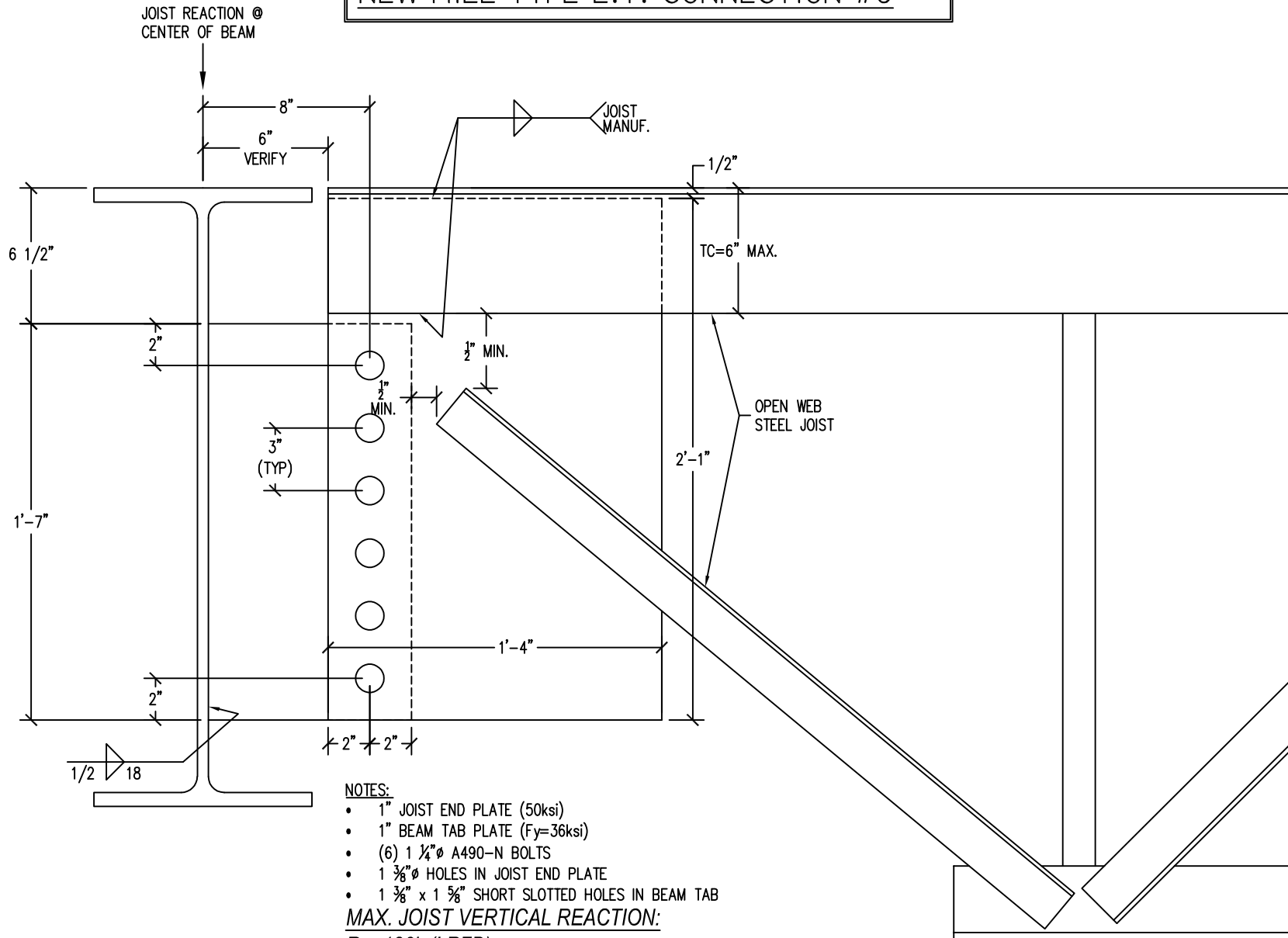

NOTES:

- 1" JOIST END PLATE (50ksi)
- 1" BEAM TAB PLATE (Fy=36ksi)
- (6) 1 1/4" ϕ A490-N BOLTS
- 1 3/8" ϕ HOLES IN JOIST END PLATE
- 1 3/8" x 1 5/8" SHORT SLOTTED HOLES IN BEAM TAB

MAX. JOIST VERTICAL REACTION:

R = 136k (LRFD)



NEW MILLENNIUM

A Steel Dynamics Company

WWW.NEWMILL.COM

Date: 9/26/2023

AISC 14TH - p. 10-104

Holes must satisfy AISC J3.2

Horizontal Axial forces (seismic or wind) if present, to be transferred from beam to joist via tie plate

Joist Plate, Fu =	65	ksi	TC Hold Back Distance (H) =	6	in
Joist Tab Plate, Fy =	50	ksi	TC Angle Size =	3.5	in
Joist Plate Width, w =	16	in	Joist Plate Hold-Down from TC =	0.5	in
Joist Plate Thickness, t =	1	in			
Joist Plate Edge Distances, de =	2	in			
e =	8	in			
Vertical Shear, Vu =	136	k (LRFD)	L ₁ =	7.5	
Vertical Ecc. Moment, Mu =	1088	k*in (LRFD)	L ₂ =	4.5	
Joist Top Chord Axial Force, V _{TC} =	204	k (LRFD)...	L ₃ =	1.5	
		Assumes 1.5:1 End Web Slope	L ₄ =	0	
Bolt Diam. =	1.25	in	L ₅ =	0	
Bolt Shear Capacity φRn =	62.7	k (A490-N)			
# of Bolts, Nb =	6	(Spreadsheet design limitation, max. 10 bolts)			
Spacing of Bolt Group, S =	3	in			
Vert. C.G. of Bolt Group =	7.5	in			
Fy/0.9 =	75.56	ksi (Table J3.2, A490-N Bolts)			
Short Slotted Hole, Lh =	1.63	in			

Gross Plate Area, Ag =	16	in ²
Effective Plate Area, Ae =	14.63	in ²
Z =	64	in ³ (1/4t*w ²)
S =	42.6667	in ³ (1/6t*w ²)

Bolt Shear - Elastic Vector Method: (AISC p. 7-8, 7-9)

Bolt Group I _p =	157.50	in ⁴ /in ²
r _{py} =	22.67	k (Vu/# Bolts)
r _{mx} =	51.81	k (Mu*L ₁ /I _p)
Hm =	51.81	k (r _{mx} *Nc) Nc = 1 column of bolts
Ru =	56.55	k (r _{py} ² +r _{mx} ²) ^{1/2}
Ru / φRn =	0.90	<1.0 OK

Shear Plate Yielding:

φVn =	480	k (φ = 1.0, φ*0.6*Fy*Ag)
Horiz. Axial Shear V _{TC} /φVn =	0.43	<1.0 OK
φMn =	1920	k*in (φ = 0.9, φ*Fy*S)
Mu/φMn =	0.57	<1.0 OK
Ru / φRn =	0.50	<1.0 OK (Vu/φVn) ² +(Mu/φMn) ²

Shear Plate Rupture: (AISC p.9-6)

Crushed Hole Width, W' =	1.4375	in (plate hole + 1/16" Crushed width)
Net Plastic Modulus, Z _{net} =	53.53	in ³ (Z - W'*t*d _{hole}) d _{hole} = 7.28125 in
φVn =	427.78	k (φ = 0.75, φ*.60*Fu*Ae)
φMn =	2609.74	k*in (φ = 0.75, φ*Fu*Z)
Ru / φRn =	0.27	<1.0 OK (Vu/φVn) ² +(Mu/φMn) ²

Shear Plate Block Shear: (AISC J4.3)

Vertical Direction		
Gross Area in Shear, Agv =	17.00	in ² (t*(d _e +(Nb-1)*S)
Net Area in Shear, Anv =	8.38	in ² Agv-(Nb*W')*t
Net Area in Tension, Ant =	1.19	in ² (t*(d _e -(Nc-0.5)*Lh), Nc = 1 column of bolts
Gross Area, φRn =	459.69	k
Net Area, φRn =	322.16	k

Horizontal Direction

Gross Area in Shear, Agv =	4.00	in ² (2*t*d _e)
Net Area in Shear, Anv =	2.38	in ² (2*t*(d _e -(Nc-0.5)*Lh), Nc = 1 column of bolts
Net Area in Tension, Ant =	7.81	in ² (t*((Nb-1)*S-(Nb-1)*W)
Gross Area, φRn =	597.81	k
Net Area, φRn =	577.28	k

φRn =	322.16	k Controls
Ru / φRn =	0.45	<1.0 OK (Vu ² +Hm ²) ^{1/2} /φRn

Shear Plate Local Buckling: (AISC p.10-103, p.9-6)

Shear Stress, fv =	12.75	ksi (V _{TC} /Ag)
Critical Stress, Fcr =	30.31	ksi ((φ*Fy) ² -3*f _v ²) ^{1/2} φ=0.75, von Mises Yield

λ =	0.08	AISC Eq. 9-18
Q =	1	AISC Eq. 9-15 through 9-17
Fcr =	50	ksi (Q*Fy) Classic Plate Buckling

von Mises φMn =	1163.82	k*in (φ*Fcr*S) φ = 0.9
Classic Plate Buckling φMn =	1920.00	k*in (φ*Fcr*S) φ = 0.9
Governing φMn =	1163.82	k*in

Mu / φMn =	0.93	<1.0 OK
------------	------	---------

Joist Plate Weld (Angle = 0 deg. & C₁ = 1.00 E70 Electrode):

Length of Plate Weld L _w =	15.5	in (w-0.5")
a _y =	0.1	AISC Table 8-4 a _y = (Weld Centroid - TC Centroid) / L _w
k _y =	0.2	AISC Table 8-4 k _y = Weld Spacing / L _w
C _y =	3.72	(y-axis weld eccentricity, AISC Table 8-4)
D _{min} =	3	/16ths of an inch Fillet Weld Size (min)

Stress Ratio Results:	
Bolt Shear (V&M):	0.90
Shear Plate Yielding:	0.50
Shear Plate Rupture:	0.27
Shear Plate Block Shear:	0.45
Shear Plate Local Buckling:	0.93

Min. Joist TC to Plate Weld:
3 / 16th x 15.5 " Fillet Weld

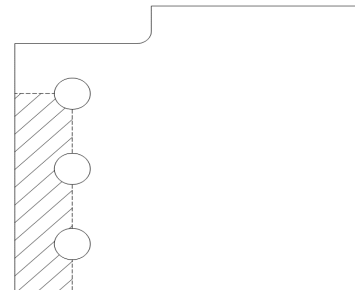

Note: Use of Lh for determination of Net Plate Area, allows for the slots to be in the joist end plate, rather than the beam tab.

Note: Use of Lh for determination of Net Plate Area, allows for the slots to be in the joist end plate, rather than the beam tab.

AISC 14TH - p. 10-104

Holes must satisfy AISC J3.2

Horizontal Axial forces (seismic or wind) if present, to be transferred from beam to joist via tie plate
cp

Beam Tab Plate, Fu =	58	ksi	
Beam Tab Plate, Fy =	36	ksi	
Beam Tab Plate Depth, d =	19	in	
Beam Tab Thickness, t =	1	in	
Beam Tab Edge Distances, d _e =	2	in	
e =	8	in	L ₁₁ = 7.5
Vertical Shear, Vu =	136	k (LRFD)	L ₁₂ = 4.5
Vertical Ecc. Moment, Mu =	1088	k*in (LRFD)	L ₁₃ = 1.5
Bolt Diam. =	1.25	in	L ₁₄ = 0
Bolt Shear Capacity φRn =	62.7	k	L ₁₅ = 0
# of Bolts, Nb =	6	(Spreadsheet design limitation, max. 10 bolts)	
Spacing of Bolt Group, S =	3	in	
C.G. of Bolt Group =	7.5	in	
Fv/0.9 =	75.56	ksi (Table J3.2, A490-N Bolts)	
Short Slotted Hole, Lh =	1.63	in	

Ab =	1.23	in ² (Bolt Area)
C =	25.09	AISC Eq. 7-21, p. 7-19
Mmax =	2326.63	k*in (Fv/0.9*Ab*C, Eq. 10-4)
Max. Beam Tab Thickness, tmax =	1.07	in (6*Mmax)/(Fy*d²) AISC Eq. 10-3
Gross Plate Area, Ag =	19	in ²
Effective Plate Area, Ae =	10.75	in ²
Z =	90.25	in ³ (1/4t*d ²)
S _{net} =	60.17	in ³ (1/6t*d ²)

Stress Ratio Results:	
Bolt Shear (V&M):	0.90
Shear Tab Yielding:	0.25
Shear Tab Rupture:	0.47
Shear Tab Block Shear:	0.51
Shear Tab Local Buckling:	0.56
8 /16" Tab Weld:	0.32
Plate Stability Acceptable	

Bolt Shear - Elastic Vector Method: (AISC p. 7-8, 7-9)

Bolt Group I _p =	157.50	in ⁴ /in ²
r _{py} =	22.67	k (Vu/# Bolts)
r _{mx} =	51.81	k (Mu*L ₁₂ /I _p)
Hm =	51.81	k (rmx*Nc) Nc = 1 column of bolts
Ru =	56.55	k (r _{py} ² +r _{mx} ²) ^{1/2}
Ru / φRn =	0.90	<1.0 OK

Shear Tab Yielding:

φVn =	410.4	k (φ = 1.0, φ*0.6*Fy*Ag)
φMn =	2924.1	k*in (φ = 0.9, φ*Fy*Z)
Ru / φRn =	0.25	<1.0 OK (Vu/φVn)²+(Mu/φMn)²

Shear Tab Rupture: (AISC p.9-6)

Crushed Hole Width, W' =	1.4375	in (plate hole + 1/16" Crushed width)
Net Plastic Modulus, Z _{net} =	51.44	in ³ (Summation of A*d of net plate section)
φVn =	280.58	k (φ = 0.75, φ*.60*Fu*Ae)
φMn =	2237.53	k*in (φ = 0.75, φ*Fu*Z)
Ru / φRn =	0.47	<1.0 OK (Vu/φVn)²+(Mu/φMn)²

Shear Tab Block Shear: (AISC J4.3)

Vertical Direction

Gross Area in Shear, Agv =	17.00	in ² (t*(d _e +(Nb-1)*S)
Net Area in Shear, Anv =	8.38	in ² Agv-(Nb*W')*t
Net Area in Tension, Ant =	1.19	in ² (t*(d _e -(Nc-0.5)*Lh), Nc = 1 column of bolts
Gross Area, φRn =	344.28	k
Net Area, φRn =	287.46	k

Horizontal Direction

Gross Area in Shear, Agv =	4.00	in ² (2*t*d _e)
Net Area in Shear, Anv =	2.38	in ² (2*t*(d _e -(Nc-0.5)*Lh), Nc = 1 column of bolts
Net Area in Tension, Ant =	7.81	in ² (t*((Nb-1)*S-(Nb-1)*W)
Gross Area, φRn =	517.93	k
Net Area, φRn =	515.11	k

φRn =	287.46 k Controls
Ru / φRn =	0.51 <1.0 OK (Vu²+Hm²)^{1/2}/φRn

Shear Tab Local Buckling: (AISC p.10-103, p.9-6)

Shear Stress, fv =	7.16	ksi (Vu/Ag)
Critical Stress, Fcr =	33.80	ksi (Fy ² -3*f _v ²) ^{1/2} von Mises Yield AISC p. 10-103

λ =	0.25	AISC Eq. 9-18
Q =	1	AISC Eq. 9-15 through 9-17
Fcr =	36	ksi (Q*Fy) Classic Plate Buckling

von Mises φMn =	2745.23	k*in (φ*Fcr*Z) φ = 0.9
Classic Plate Buckling φMn =	1949.40	k*in (φ*Fcr*Z) φ = 0.9

Governing φMn = 1949.40 k*in

Mu / φMn =	0.56 <1.0 OK
------------	------------------------

Shear Tab Weld: (AISC p.10-102, p.9-6)

Min. Weld Thickness t _{wmin} =	0.45	in. t _{wmin} = (t*Fy*3 ^{1/2})/(2*F _{EXX}), F _{EXX} = 70ksi Electrode, AISC Engineering Journal, Vol. 46, 2009
Weld Provided t _w =	0.5	in
Min. Plate Thickness =	0.85	in (AISC Eq. 9-3, 6.19*D/Fu) GOOD
φRw =	423.14	k (φ*0.6*F _{EXX} *0.707*t _w *d*2)

Ru / φRn =	0.32 <1.0 OK
------------	------------------------

Shear Tab Stability: (Thornton and Fortney, 2011)

Lateral Torsional Buckling Check:

φRn =	1259	k Acceptable
-------	------	---------------------

$R_{req'd} \leq \phi R_n$ (LRFD)

$R_n = 1500\pi \frac{I_p^3}{a^2}$

I = beam tab plate length (depth)
t = tp = beam tab plate thickness
a = Eccentricity 'e'

Lap Splice Eccentricity Check:

φMt,u =	137.2	k*in
Mt,u =	136.0	k*in (R*(t _p +t _j)/2)

$M_{t,u} \leq \left[\phi_v \left(0.6F_{yp} \right) \frac{R_u}{I_p} \right] \frac{I_p^2}{2}$

(LRFD)

$\phi_v = 1.0$

Acceptable

